

技术参数 Specifications

电气参数 Ratings:

- ◇最大工作电压
Max. Switching Voltage: 1500VDC
- ◇额定电流
Rated Current: 100A
- ◇主触点形式
Main Contact Type: 一组常开 SPST-NO
- ◇辅助触点
Auxiliary Contact: 可选配 Optional
- ◇辅助触点形式
Auxiliary Contact Type: 一组常开 SPST-NO
- ◇线圈额定电压
Coil Rated Voltage : 12VDC/24VDC/48VDC
- ◇使用环境温度
Ambient Operation Temperature : -40°C~+85°C
- ◇使用环境湿度
Ambient Operation Humidity : 5%~85%RH



认证/标准 Approvals/Standard:

- ◇REACH
- ◇RoHS
- ◇UL 60947-4
- ◇CCC/CE/CB/S Mark

产品特征 Features&Benefits:

- 陶瓷密封结构，腔内充有氢气混合气体，无电弧泄露风险，接触电阻低且稳定；
Ceramic sealing structure with H₂ mixed gas filled in the chamber, no risk of arc leakage, low&stable contact resistance;
- 良好的抗短路能力，确保通过短路电流，触头仍能可靠闭合不斥开，产品不起火不爆炸；
High value of short-circuit current withstanding to ensure the contacts can be reliably closed when encountering short-circuit current, contributing to no risk of fire and explosion;
- 无极性灭弧设计，安装方向不敏感，适用回路双向电流的各种场景，使用安全可靠；
Non-polarity arc extinguishing design that is applicable to a range of scenarios with bidirectional current circuit safely and reliably;
- 可选配一组常开辅助触点；
A set of NO auxiliary contacts is optional;
- 能够在85°C环境下持续承载100A电流；
Carrying current 100A continuously at 85°C;

产品型号说明 Product Model:

	HC	F	100	B/	1500	-12	H	C	1	H	□	- ()
公司代码 Company Code												
系列代码 Series Code	F:方形系列 Square Series											
触点容量(额定电流) Contact Rating(Rated Current)	100:100A											
衍生型号 Derivative Model	B:衍生型 Derivative Model											
负载电压 Load Voltage	450:450VDC; 800:800VDC; 1000:1000VDC; 1500:1500VDC											
线圈电压 Coil Voltage	12:12VDC; 24:24VDC; 48:48VDC											
主触点形式 Main Contact Type	H: 一组常开 SPST-NO											
线圈出线方式 Coil Input Terminal	C: 连接器 Connector											
负载引出端方式 Load Input Terminal	1: 内螺纹 Internal Thread											
辅助触点 Auxiliary Contact	无 Nil: 无辅助触点 No Auxiliary Contact; H: 一组常开 SPST-NO											
安装形式 Mounting	无 Nil: 立体安装 Vertical Mounting											
特性号 Special Code	XXX: 客户特殊要求 Customer Special Code; 无 Nil: 标准型 Standard											

HCF100B/□-□HC1

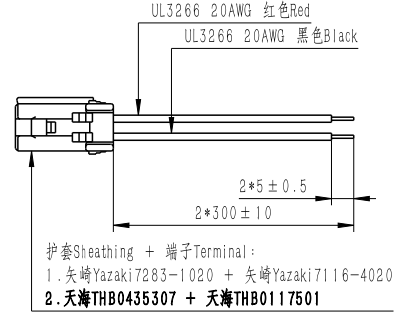
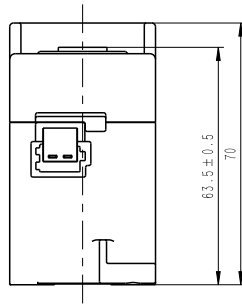
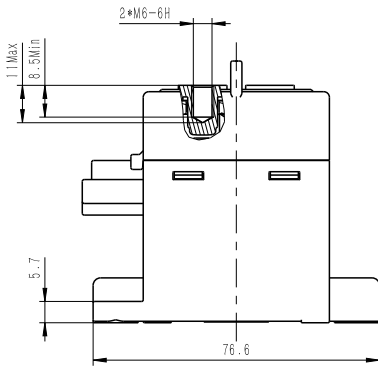

护套Sheathing + 端子Terminal:
1. 矢崎Yazaki7283-1020 + 矢崎Yazaki7116-4020
2. 天海THB0435307 + 天海THB0117501

线圈连接器(选配)
Coil Connector(Optional)

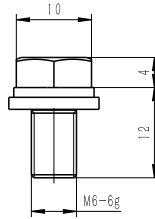
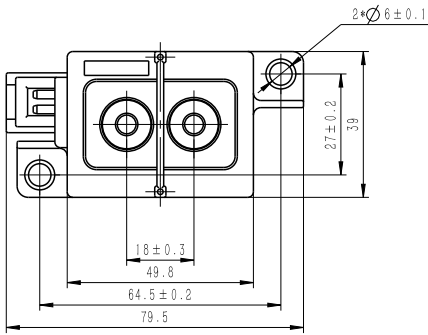

组合螺钉示意(选配)
Combination Screw(Optional)

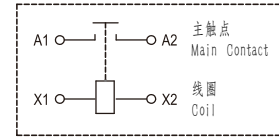

接线图
Coil Wiring Diagram

未注公差 General Tolerance:
< 10mm: ± 0.3mm
10-50mm: ± 0.5mm
> 50mm: ± 0.8mm

特性参数 CHARACTERISTIC PARAMETERS

主触点参数 MAIN CONTACT DATA

最大工作电压 Max.Switching Voltage	1500VDC	额定电流 Rated Current	100A	
触点形式 Contact Arrangement	一组常开 SPST-NO	触点压降 Contact Voltage Drop	≤0.05V(at 100A)	
短时承载电流 Limiting Short-time Current	150A:120min; 200A:30min; 400A:60s; 1000A:1s			
电寿命(阻性负载) Electrical Life(Resistive Load)	450V 型 Model	800V 型 Model	1000V 型 Model	1500V 型 Model
	100A 450VDC 3000 次(ops)	100A 800VDC 1000 次(ops)	100A 1000VDC 500 次(ops), 仅分断 Only Breaking	15A 1500VDC 6000 次(ops); 30A 1500VDC 11000 次(ops) 仅接通 Only Making;
最大分断电流(阻性负载) Max.Breaking Current (Resistive Load)	1000A 450VDC 1 次(ops)			
过载分断(阻性负载) Overload Breaking(Resistive Load)	300A 450VDC 100 次(ops)			

性能参数 CHARACTERISTIC DATA

介质耐压 Dielectric Strength	触点与线圈间 Between Main Contacts And Coil	试验前 Before Test ≥ 4000VAC (1min) 试验后 After Test ≥ 2500VAC (1min)	绝缘电阻 Insulation Resistance	触点与线圈间 Between Main Contacts And Coil	试验前 Before Test ≥ 1000MΩ (1000VDC) 试验后 After Test ≥ 50MΩ (1000VDC)
	断开触点间 Between Open Main Contacts	试验前 Before Test ≥ 3000VAC (1min) 试验后 After Test ≥ 2500VAC (1min)		断开触点间 Between Open Main Contacts	试验前 Before Test ≥ 1000MΩ (1000VDC) 试验后 After Test ≥ 50MΩ (1000VDC)
耐冲击 Shock Resistance	功能性 Functional	20g 半正弦波 Half-Sine Wave 11ms	耐振动 Vibration Resistance	功能性 Functional	5.79g (10~2000HZ, 随机 Random)
	强度 Destructive	50g 半正弦波 Half-Sine Wave 6ms			
吸合时间 Operate Time	Max:30ms		机械寿命 Mechanical Life	2*10 ⁵ 次(ops)	
释放时间 Release Time	Max:10ms		重量 Weight	约 Approx 350g	

线圈参数 COIL DATA

额定电压 Rated Voltage	12VDC	24VDC	48VDC
吸合电压 Pick-up Voltage	≤9VDC	≤18VDC	≤36VDC
释放电压 Drop-out Voltage	≥1.2VDC	≥2.4VDC	≥4.8VDC
线圈功率 Rated Operating Power	约 Approx 6W	约 Approx 6W	约 Approx 6W
最大允许电压 Max.Allowable Voltage	16VDC	32VDC	64VDC

HCF100B/□-□HC1H

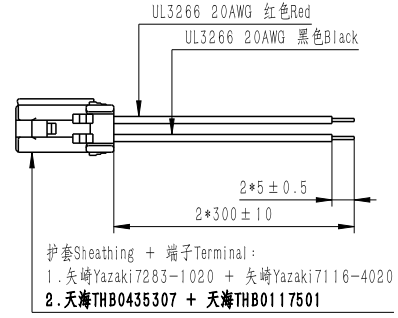
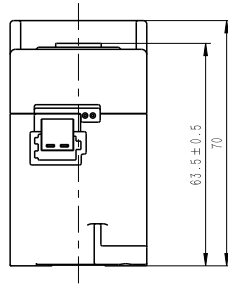
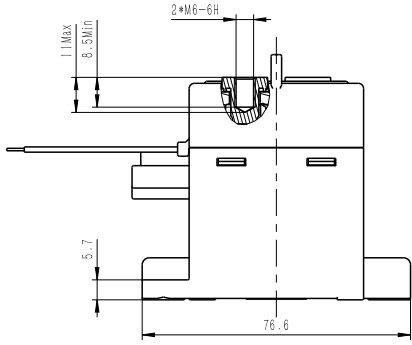

线圈连接器(选配)
Coil Connector(Optional)

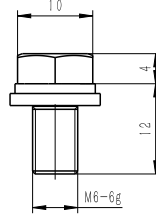
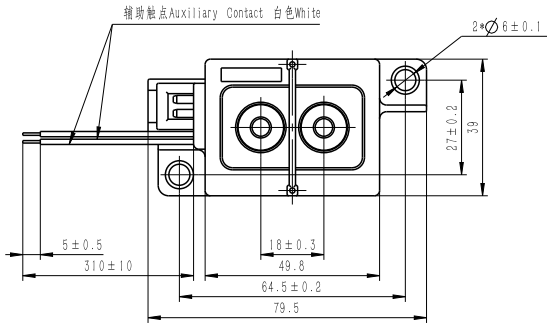

组合螺钉示意(选配)
Combination Screw(Optional)

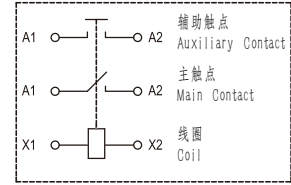

接线图
Coil Wiring Diagram

未注公差 General Tolerance:
< 10mm: ± 0.3mm
10~50mm: ± 0.5mm
> 50mm: ± 0.8mm

特性参数 CHARACTERISTIC PARAMETERS

主触点参数 MAIN CONTACT DATA

最大工作电压 Max.Switching Voltage	1500VDC	额定电流 Rated Current	100A
触点形式 Contact Arrangement	一组常开 SPST-NO	触点压降 Contact Voltage Drop	≤0.05V(at 100A)
短时承载电流 Limiting Short-time Current	150A:120min; 200A:30min; 400A:60s; 1000A:1s		
电寿命 (阻性负载) Electrical Life(Resistive Load)	450V 型 Model	800V 型 Model	1000V 型 Model
	100A 450VDC 3000 次(ops)	100A 800VDC 1000 次(ops)	100A 1000VDC 500 次(ops), 仅分断 Only Breaking
最大分断电流 (阻性负载) Max.Breaking Current (Resistive Load)	1000A 450VDC 1 次(ops)		
过载分断 (阻性负载) Overload Breaking(Resistive Load)	300A 450VDC 100 次(ops)		

性能参数 CHARACTERISTIC DATA

介质耐压 Dielectric Strength	触点与线圈间 Between Main Contacts And Coil	试验前 Before Test ≥4000VAC (1min) 试验后 After Test ≥2500VAC (1min)	绝缘电阻 Insulation Resistance	触点与线圈间 Between Main Contacts And Coil	试验前 Before Test ≥1000MΩ (1000VDC) 试验后 After Test ≥50MΩ (1000VDC)
	断开触点间 Between Open Main Contacts	试验前 Before Test ≥3000VAC (1min) 试验后 After Test ≥2500VAC (1min)		断开触点间 Between Open Main Contacts	试验前 Before Test ≥1000MΩ (1000VDC) 试验后 After Test ≥50MΩ (1000VDC)
	触点与辅助触点间 Between Main Contacts And Auxiliary Contacts	试验前 Before Test ≥3000VAC (1min) 试验后 After Test ≥2500VAC (1min)		触点与辅助触点间 Between Main Contacts And Auxiliary Contacts	试验前 Before Test ≥1000MΩ (1000VDC) 试验后 After Test ≥50MΩ (1000VDC)
耐冲击 Shock Resistance	功能性 Functional	20g 半正弦波 Half-Sine Wave 11ms	耐振动 Vibration Resistance	功能性 Functional	5.79g (10~2000HZ, 随机 Random)
	强度 Destructive	50g 半正弦波 Half-Sine Wave 6ms			
吸合时间 Operate Time	Max:30ms	机械寿命 Mechanical Life	2*10 ⁵ 次(ops)		
释放时间 Release Time	Max:10ms	重量 Weight	约 Approx 350g		

线圈参数 COIL DATA

额定电压 Rated Voltage	12VDC	24VDC	48VDC
吸合电压 Pick-up Voltage	≤9VDC	≤18VDC	≤36VDC
释放电压 Drop-out Voltage	≥1.2VDC	≥2.4VDC	≥4.8VDC
线圈功率 Rated Operating Power	约 Approx 6W	约 Approx 6W	约 Approx 6W
最大允许电压 Max.Allowable Voltage	16VDC	32VDC	64VDC

辅助触点参数 AUXILIARY CONTACT DATA

辅助触点形式 Auxiliary Contact Arrangement	一组常开 SPST-NO	辅助触点使用范围 Auxiliary Contact Range	100mA/8VDC~2A/30VDC
辅助触点电阻 Auxiliary Contact Resistance	≤200mΩ (at 100mA)		

电流承载曲线 Current Carry Curve:

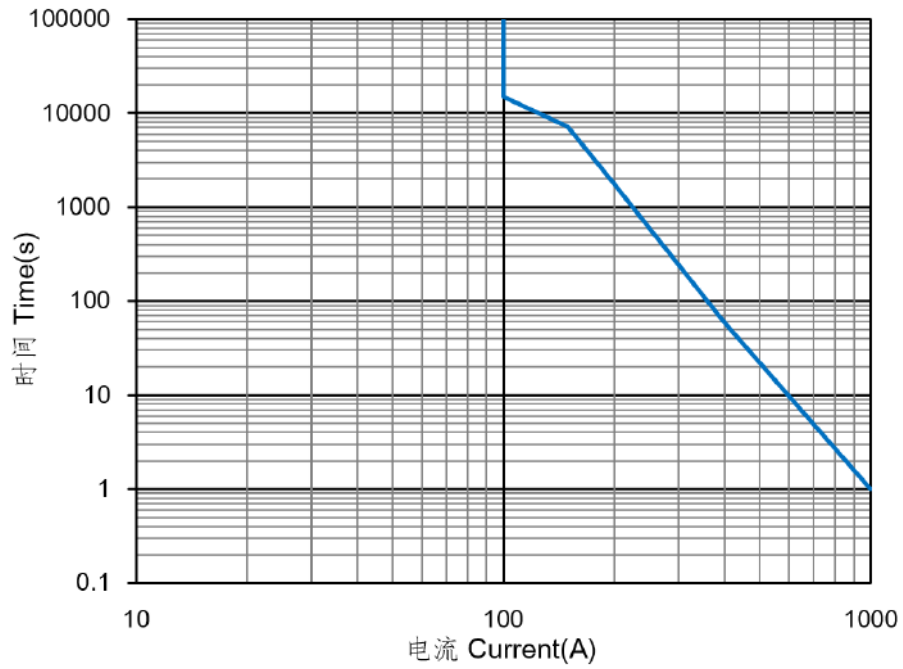

寿命曲线 Life Span Curve:

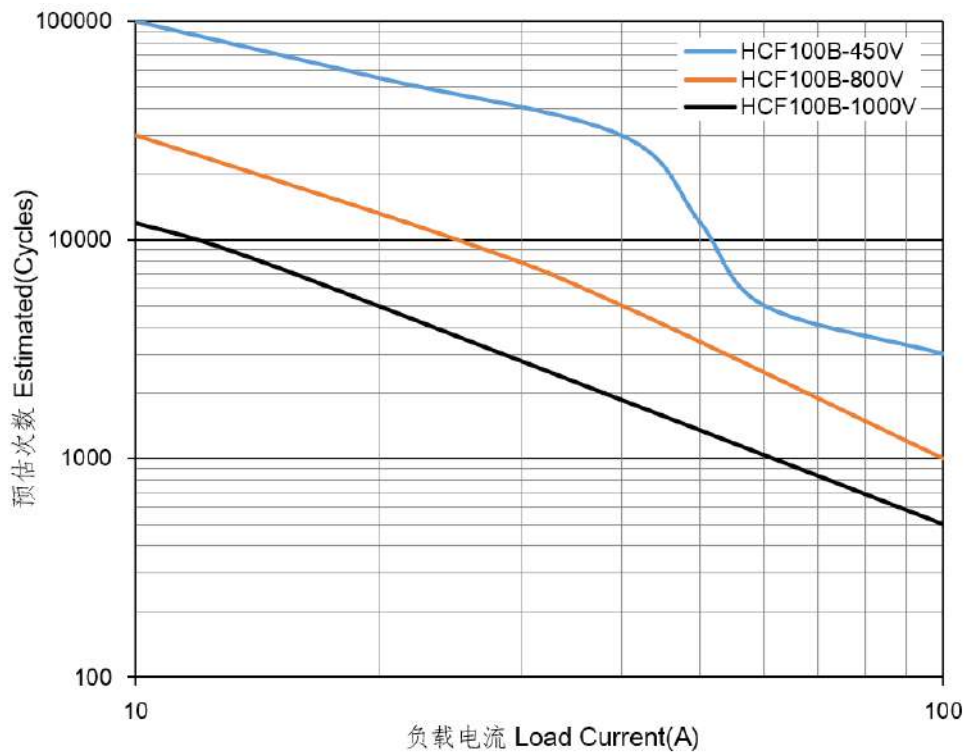

使用注意事项 Caution:

- 规格书内的各项性能参数是基于标准测试条件下测得的初始值。
All the performance parameters listed in this specification are deemed as initial value measured under standard testing conditions.
- 使用环境温度-40°C~+85°C，湿度5%~85%RH。
Used in environment temperature -40°C~+85°C, humidity 5%~85%RH.
- 请避免安装在强磁场（变压器、磁铁周围）或发热物体附近。
Please avoid installing the device near high magnetic fields (eg.transformers or magnetics) or hot objects.
- 电寿命试验为阻性负载时的数值，应用在L/R≥1ms的感性负载回路时，请与感性负载并行采取浪涌吸收措施。未采取措施的情况下，可能会成电气寿命下降、发生切断不良。
The electrical life test is performed with resistive load. Therefore, please take surge absorption measures in parallel with inductive load when the device is applied to inductive load circuit with L/R≥1ms. Otherwise, the electrical life is likely to decline, resulting in poor cutting off.
- 应用在容性负载回路时，请注意采取预充等措施，建议接触器闭合压差控制在20V以内。如未采取措施，可能会造成触点粘连。
Measures including precharging etc. must be taken if the device is to be applied in capacitive load circuit. It is suggested that the differential pressure be controlled within 20V when the contactor is in closed position. Otherwise, it might lead to contact adhesion.
- 为抑制接触器线圈的反电动势，建议加装非线性电阻（推荐使用可变电阻，最大能量耐量：1J以上；电压：额定电压的1.5~2倍）。若使二极管，会使接触器释放时间加长，会导致切断性能下降，请注意。
It is recommended to install a non-linear resistor (Variable resistors are preferred with over 1J maximum energy tolerance and 1.5-2 times of rated voltage) to suppress the reverse electromotive force generating from the contactor coil. Please be noted that the using of diode will prolong the release time of contactor, leading to degradation of cut-off performance.
- 请避免在引出端上粘附油脂等异物，建议使用35mm²以上规格导线，否则有可能造成引出端异常发热。
Please avoid adhering such foreign matters as grease etc. on the leading-out terminals. Over 35mm² conductors shall be used. Otherwise, it will casue abnormal heating of leading-out terminals.
- 请避免在使用或运输过程中发生撞击或跌落。为保持产品的性能，撞击或跌落后不建议继续使用。
Please avoid collision or falling during use or transportation. In order to maintain the performance of the product, it is not recommended to continue to use it after impact or fall.
- 当产品使用1个及多个导电铜排连接时，请确保导电铜排与触点端面紧密贴合（多个铜排需确保大电流的导电铜排最贴近触点端面，小电流的导电铜排其次），然后是平垫圈、弹簧垫圈、螺钉。不正确的连接顺序可能造成严重过热，参考下图1：
When the product is connected with one or more conductive copper bars, please ensure that the conductive busbars closely fit the contact terminal surface (The conductive copper bars with high current must be closet to the contact terminal surface if there are multiple copper bars and then conductive busbars with low current), followed by flat washers, spring washers and screws. Incorrect connection sequence perhaps give rise to severe overheating. Refer to Figure 1 as follows:
- 螺钉安装时，螺纹咬合深度不能过浅，否则有可能导致滑牙松脱，建议咬合深度至少螺纹深度的2/3。
When installing the screws, the thread engagement depth shall not be too shallow, otherwise it may cause the sliding teeth to become loose. It is recommended that the engagement depth be at least 2/3 of the thread depth.
- 为防止出现松动，接触器安装时请使用垫圈螺钉锁紧，各部位的螺钉锁紧扭矩请控制在以下范围：

主负载安装部位 Main loading installation part				接触器壳体安装部位(图2) Contactor shell installation department (figure 2)		
安装方式 Installation method	扭矩要求 Torque requirements	铜排孔径 Diameter of busbar	铜排厚度 Busbar thickness	安装方式 Installation method	扭矩要求 Torque requirements	底板孔径 Diameter of baseboard
M6螺钉 Screw	6N·m~8N·m	Ø6mm~Ø6.5mm	2mm	M5螺钉 Screw	3N·m~4N·m	M5

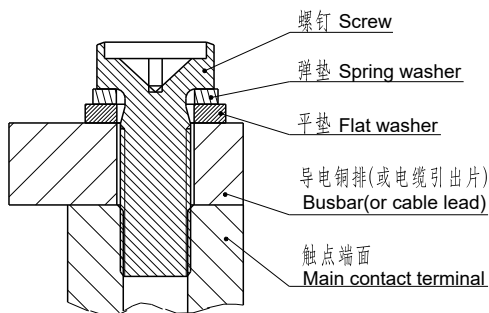

图1(Fig1)

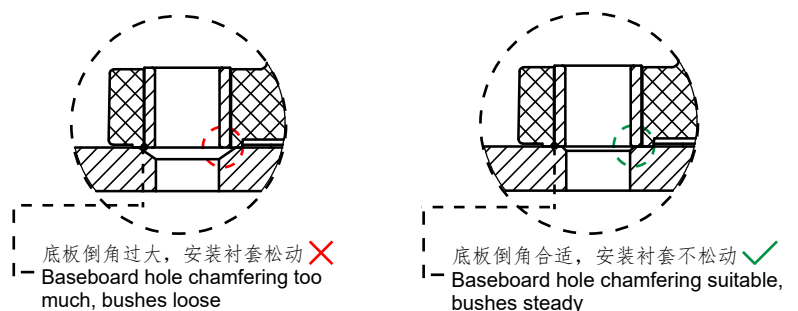

图2(Fig2)