

## HCZ01-200 Specifications

### Ratings:

- ◇ Max. Switching Voltage: 1000VDC
- ◇ Rated Current: 200A
- ◇ Main Contact Type: SPST-NO
- ◇ Auxiliary Contact: SPST-NO/NC
- ◇ Auxiliary Contact Type: Optional
- ◇ Ambient Operation Temperature : -40°C~+85°
- ◇ C Ambient Operation Humidity : 5%~85%RH
- ◇



### Approvals/Standard:

- ◇ REACH
- ◇ RoHS
- ◇ CE
- ◇ UL

### Features&Benefits:

Compact structure, fully sealed package, internal filled with inert gas, combined with magnetic arc blowing out can quickly extinguish the arc, so that the product shape can be small;

Epoxy resin package, the contact part is sealed in thesealed chamber filled with inert gas, contact no oxidation, arc noeakage, so as to ensure that the product has good safety;

Carrying current 200A continuously at 85°C;

Product Model:	
	HC Z01 - 200 F -A P - ( )
Company Code	
Series Code	Z01 Series
Contact Rating(Rated Current)	200:200A
Auxiliary Contact	Nil: No Auxiliary Contact F: SPST-NO B: SPST-NC
Coil Voltage	12:12V, 24:24V, A :12-36VDC, 48: 48~72VDC
Main Contact Type	Nil: SPST-NO, Non-Polarized P: SPST-NO, Polarized
Special Code	XXX: Customer Special Code; Nil: Standard

## Characteristic parameter

MAIN CONTACT DATA					
Max. Switching Voltage	1000VDC	Rated Current	200A (@60mm <sup>2</sup> wire)		
Contact Arrangement	SPST-NO	Contact Voltage Drop	≤0.06V(at 200A)		
Limiting Short-time Current	300A:900s; 400A:180s				
Electrical Life (Resistive Load)	200A 450VDC 6000 ops	200A 750VDC 2000 ops	200A 1000VDC 1000 ops		
Max.Breaking Current(Resistive Load)	2000A 320Vdc 1ops				
CHARACTERISTIC DATA					
Dielectric Strength	Between Main Contacts and Coil	Before Test≥3500VAC (1min)	Insulation Resistance	Between Main Contacts and Coil	Before Test≥1000MΩ (1000VDC) After Test≥50MΩ (1000VDC)
	Between Open Main Contacts	Before Test≥3500VAC (1min)		Between Open Main Contacts	Before Test≥1000MΩ (1000VDC) After Test≥50MΩ (1000VDC)
Shock Resistance	Functional	196m/s <sup>2</sup> 20G above	Vibration Resistance	Functional	10~500Hz,49m/s <sup>2</sup>
	Destructive	490m/s <sup>2</sup> 50G above			
Operate Time	Max:30ms		Mechanical Life	2*10 <sup>5</sup> ops	
Release Time	Max:10ms		Weight	Approx 380g	
Auxiliary contact parameters					
Switch Rating	30Vd.c. 2A;125Va.c. 3A		Minimum Load	5Vd.c. 100mA	
Auxiliary Resistance	≤150mΩ				
COIL DATA					
Rated Voltage	12-36VDC		48-72VDC		
Pick-up Voltage	≤ 9VDC		≤28VDC		
Drop-out Voltage	≥6VDC		≥16 VDC		
Rated Operating Power	Starting power 40W (About 0.1 s) Hold power 2.2W (About 0.1 s)				
Coil Resistance	3.2 Ω ± 7%		40 Ω ± 7%		

## Wiring diagram

Load non-polar, no auxiliary

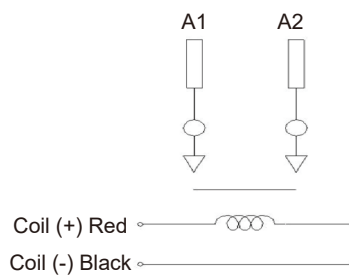

The load is polar , no auxiliary

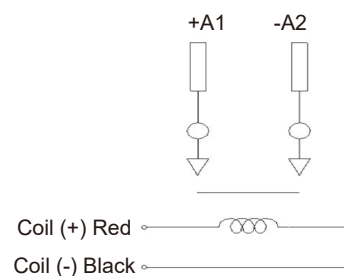

Load non-polar, with normally open auxiliary contact

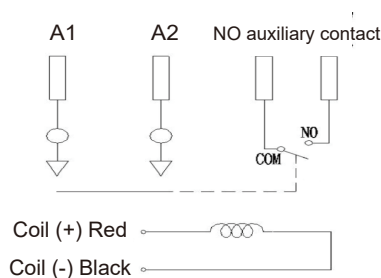

Load non-polar, with normally closed auxiliary contact

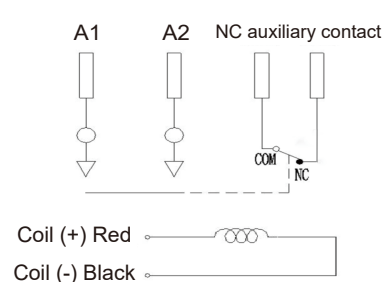

## Outline dimensional

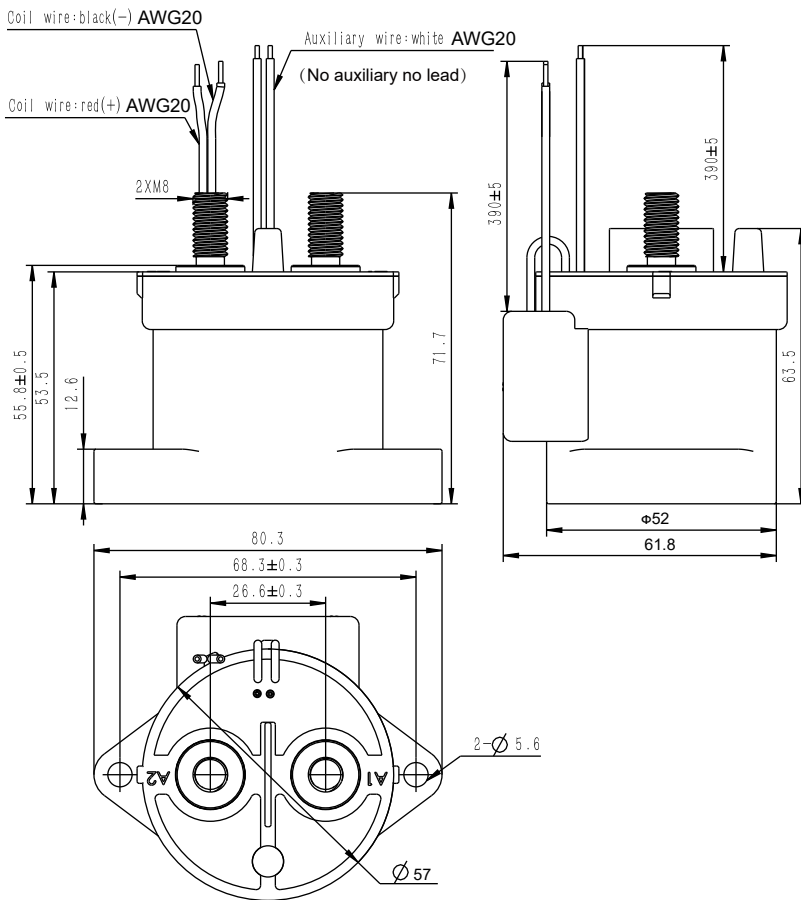

## Caution:

- 1.All the performance parameters listed in this specification are deemed as initial value measured under standard testing conditions.
- 2.Used in environment temperature  $-40^{\circ}\text{C}\sim+85^{\circ}\text{C}$ , humidity 5%~85%RH.
- 3.Please avoid installing the device near high magnetic fields (eg.transformers or magnetics) or hot objects.
- 4.The electrical life test is performed with resistive load. Therefore, please take surge absorption measures in parallel with inductive load when the device is applied to inductive load circuit with  $L/R\geq 1\text{ms}$ . Otherwise, the electrical life is likely to decline, resulting in poor cutting off.
- 5.Measures including precharging etc. must be taken if the device is to be applied in capacitive load circuit.It is suggested that the differential pressure be controlled within 20V when the contactor is in closed position. Otherwise, it might lead to contact adhesion.
- 6.It is recommended to install a non-linear resistor(Variable resistors are preferred with over 1J maximum energy tolerance and 1.5-2 times of rated voltage)to suppress the reverse electromotive force generating from the contactor coil. Please be noted that the using of diode will prolong the release time of contactor, leading to degradation of cut-off performance.
- 7.Please avoid adhering such foreign matters as grease etc. on the leading-out terminals. Over 60mm<sup>2</sup> conductors shall be used. Otherwise, it will casue abnormal heating of leading-out terminals.
- 8.Please avoid collision or falling during use or transportation. In order to maintain the performance of the product, it is not recommended to continue to use it after impact or fall.

9. When the product is connected with one or more conductive copper bars, please ensure that the conductive busbars closely fit the contact terminal surface (The conductive copper bars with high current must be closet to the contact terminal surface if there are multiple copper bars and then conductive busbars with low current), followed by flat washers, spring washers and screws. Incorrect connection sequence perhaps give rise to severe overheating. Refer to Figure 1 as follows:

10. When installing the screws, the thread engagement depth shall not be too shallow, otherwise it may cause the sliding teeth to become loose. It is recommended that the engagement depth be at least 2/3 of the thread depth.

11. To prevent looseness, the contactor shall be locked with washer screws during installation, and the screw locking torque of each part shall be controlled within the following range:

Main loading installation part				Contactor shell installation department (figure 2)		
Installation method	Torque requirements	Diameter of busbar	Busbar thickness	Installation method	Torque requirements	Diameter of baseboard
M8 Screw	8.0N·m~10.0N·m	Ø8mm~Ø8.5mm	2.5~4mm	M5 Screw	3.0N·m~4.0N·m	M5

12 . Period of Validity: Two years

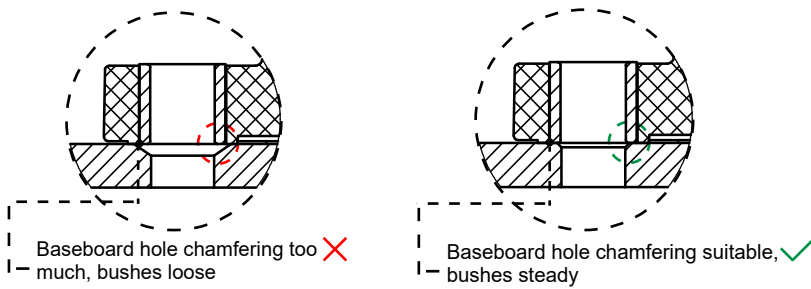

Fig2